



Minipack-torre S.p.A.
Via Provinciale, 54 - 24044 Dalmine (BG) - Italy
Tel. (035) 563525 – Fax (035) 564945
E-mail: info@minipack-torre.it
<http://www.minipack-torre.it>



Catalogo ricambi
(Valido dalla matricola nr. 101 del 02.2000)
Spare parts catalogue
(Valid from serial number 101 dated 02.2000)

Media 50

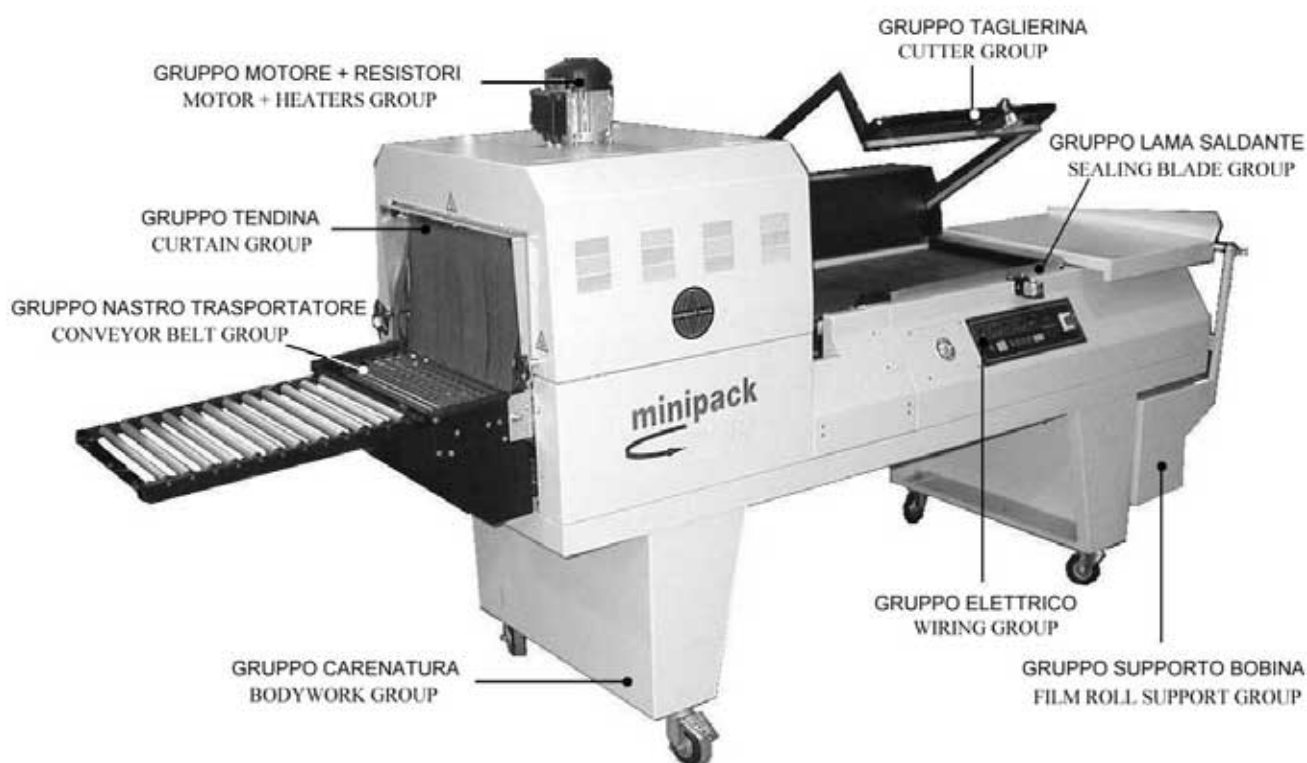

Consultare attentamente questo libretto prima di ordinare pezzi di ricambio
Carefully read this booklet before ordering spare parts



DOC. N. FM112017
REV. 01
ED. 03.2004

УПАКОВОЧНОЕ ОБОРУДОВАНИЕ



ПРОИЗВОДСТВО И ПОСТАВКА
СЕРВИСНЫЙ РЕМОНТ
ЗАПАСНЫЕ ЧАСТИ
РАСХОДНЫЕ МАТЕРИАЛЫ

Диагностика, ремонт, сервисное обслуживание.

Запасные части и расходный материал: резина, тефлоновая лента, термонож (лезвие), гель для смазки.

Плѐнка термоусадочная полиолефиновая.

Система «Trade-In» – замена Вашего оборудования на новое и более производительное.



На фото: запайщик Magnetic FL900 + туннель Magnetic T100

ООО «АРДсистемы» (495) 231-21-00
(812) 363-20-22
info@ardsystems.ru

www.filmtrade.ru www.ardsystems.ru

INDICE GRUPPI DI RICAMBIO / INDEX OF SPARE PARTS GROUPS

| TAVOLA NR. SCHEME N. | DESCRIZIONE DESCRIPTION | PAGINA PAGE |
|---------------------------------|--|------------------------|
| 1 | GRUPPO LAMA SALDANTE SEALING BLADE GROUP | 2 |
| 2 | GRUPPO TAGLIERINA CUTTER GROUP | 3 |
| 3 | GRUPPO SUPPORTO BOBINA FILM ROLL SUPPORT GROUP | 4 |
| 4 | GRUPPO NASTRO TRASPORTATORE TRANSPORT BELT GROUP | 5 |
| 5 | GRUPPO CARENATURA BODYWORK GROUP | 6 |
| 6 | GRUPPO NASTRO TRASPORTATORE (ingresso tunnel) CONVEYOR BELT GROUP (tunnel inlet side) | 7 |
| 7 | GRUPPO NASTRO TRASPORTATORE (uscita tunnel) CONVEYOR BELT GROUP (tunnel outlet side) | 8 |
| 8 | GRUPPO NASTRO TRASPORTATORE (interno tunnel) CONVEYOR BELT GROUP (tunnel inside) | 9 |
| 8A | GRUPPO NASTRO TRASPORTATORE (catena) CONVEYOR BELT GROUP (chain) | 9 |
| 8B | GRUPPO NASTRO TRASPORTATORE (teflon) CONVEYOR BELT GROUP (teflon) | 9 |
| 9 | GRUPPO MOTORE+RESISTORI MOTOR+HEATERS GROUP | 10 |
| 9A | GRUPPO TENDINE CURTAIN GROUP | 10 |
| 10 | GRUPPO ELETTRICO (pannello comandi) WIRING GROUP (control panel) | 11 |
| 10A | GRUPPO ELETTRICO (cassetto) WIRING GROUP (box) | 11 |
| | SCHEMA ELETTRICO WIRING DIAGRAM | 12 |
| | LEGENDA SCHEMA ELETTRICO WIRING DIAGRAM | 13 |

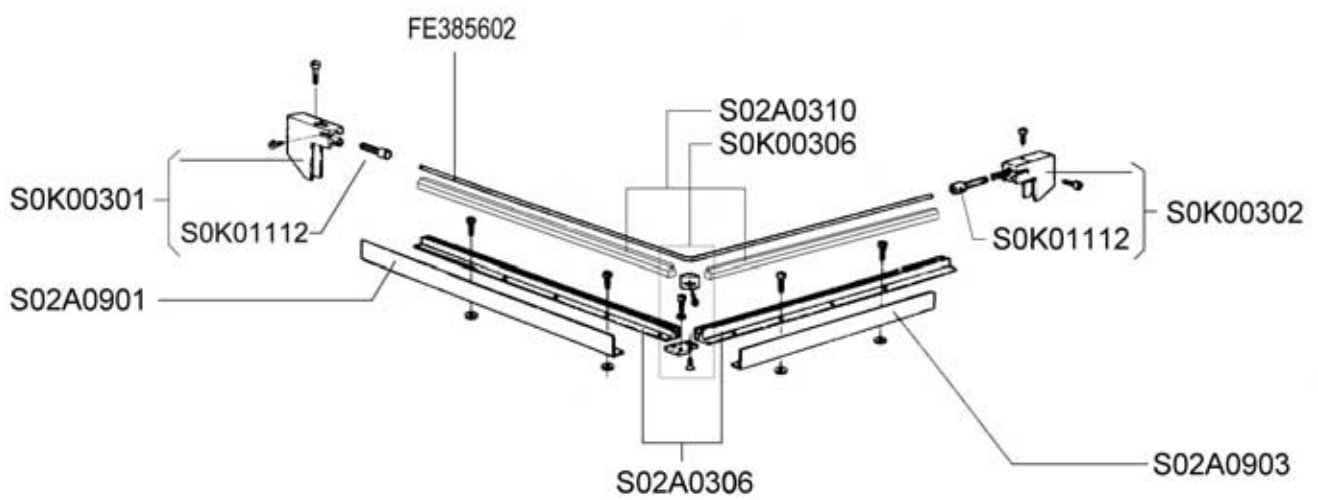

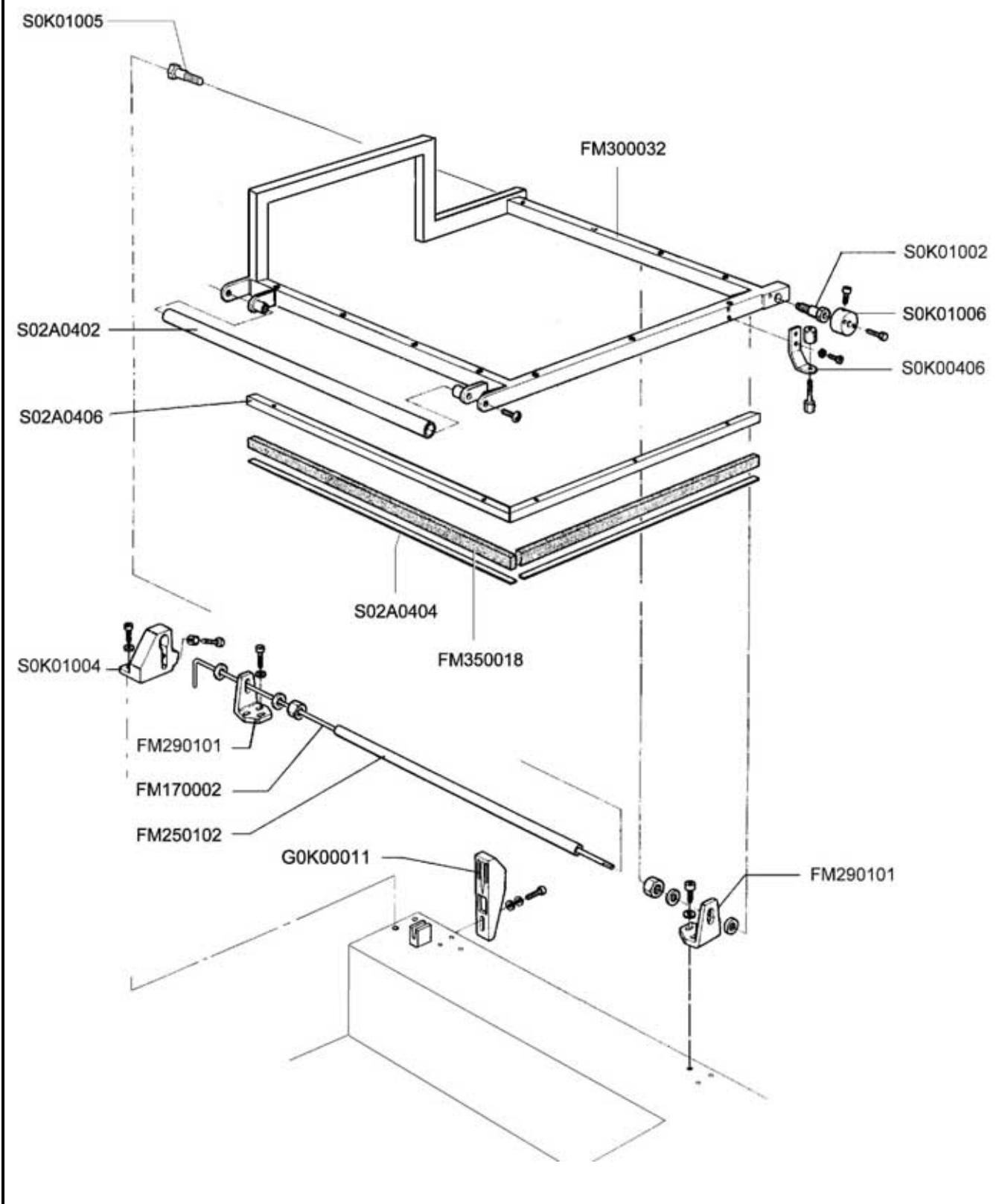

PB17B001: Kit supporto bobina
Film roll support kit

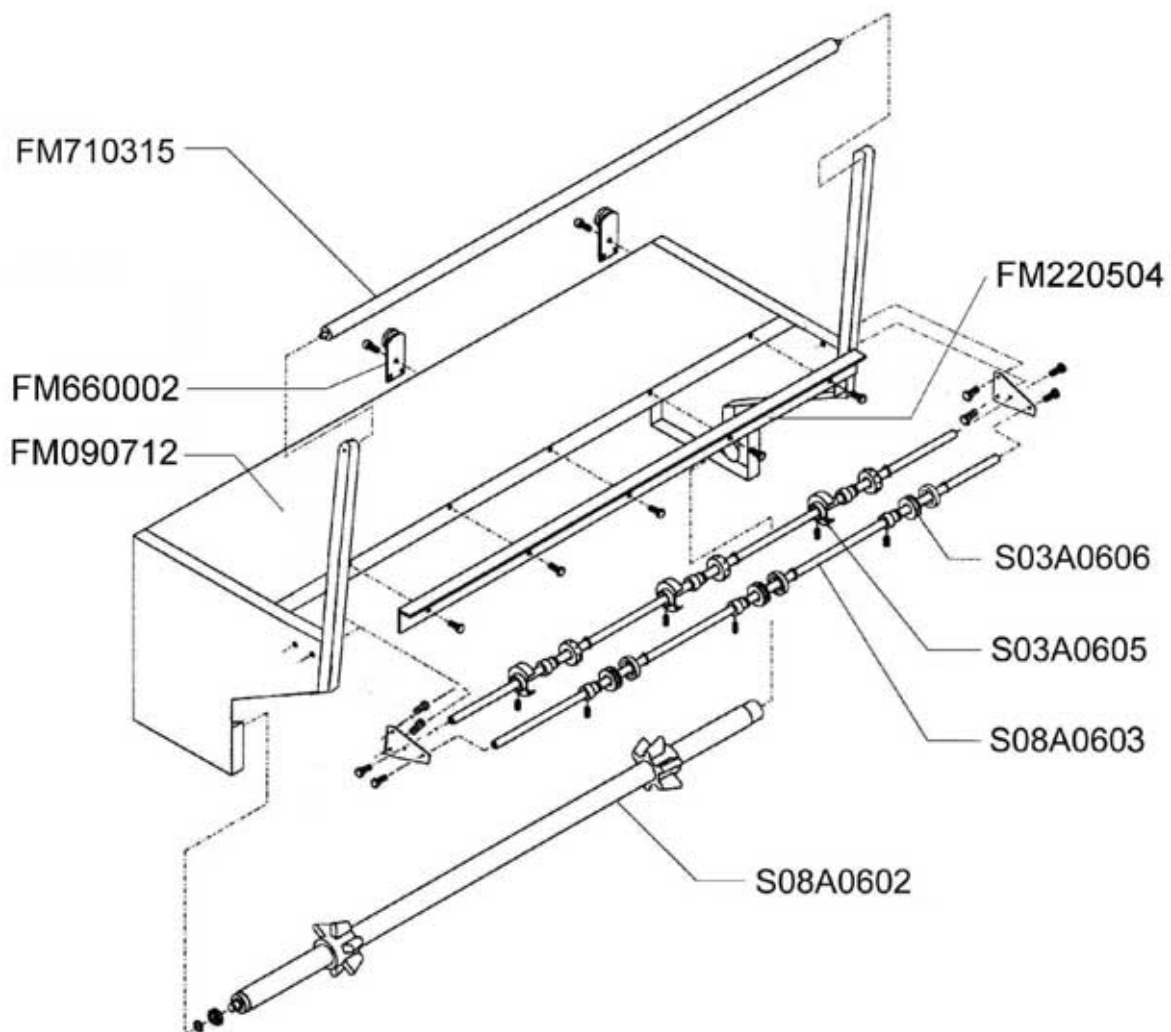

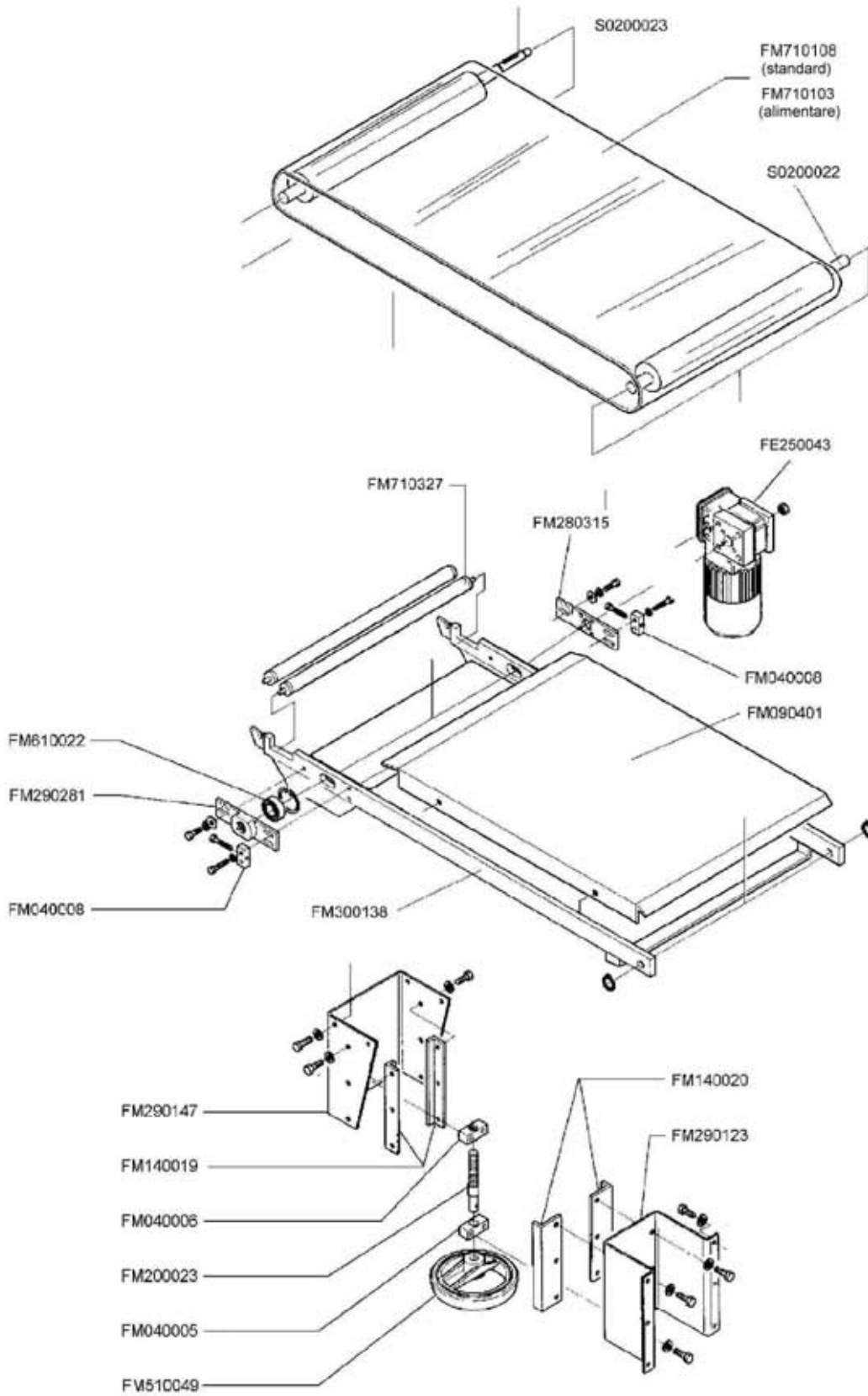

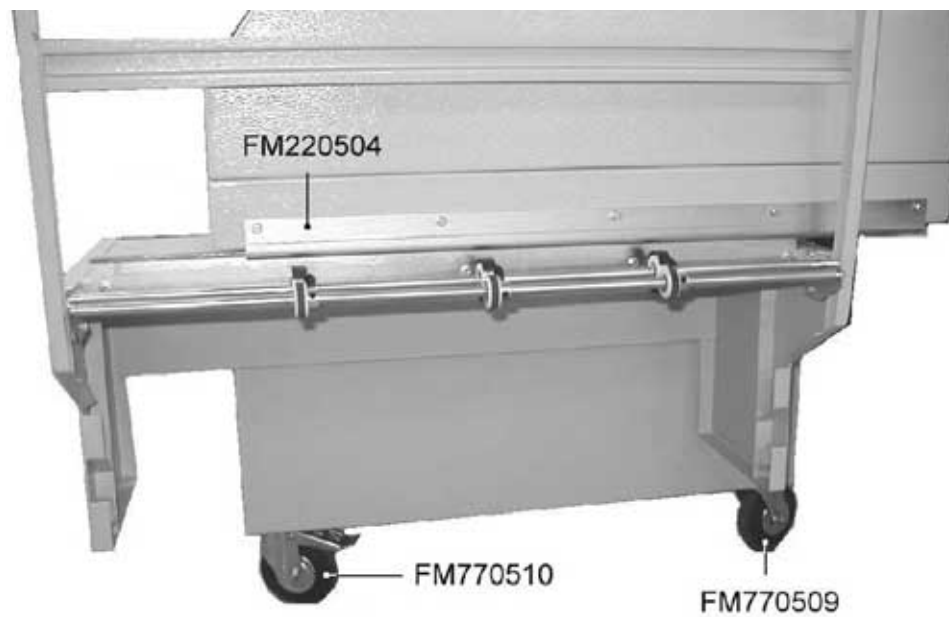
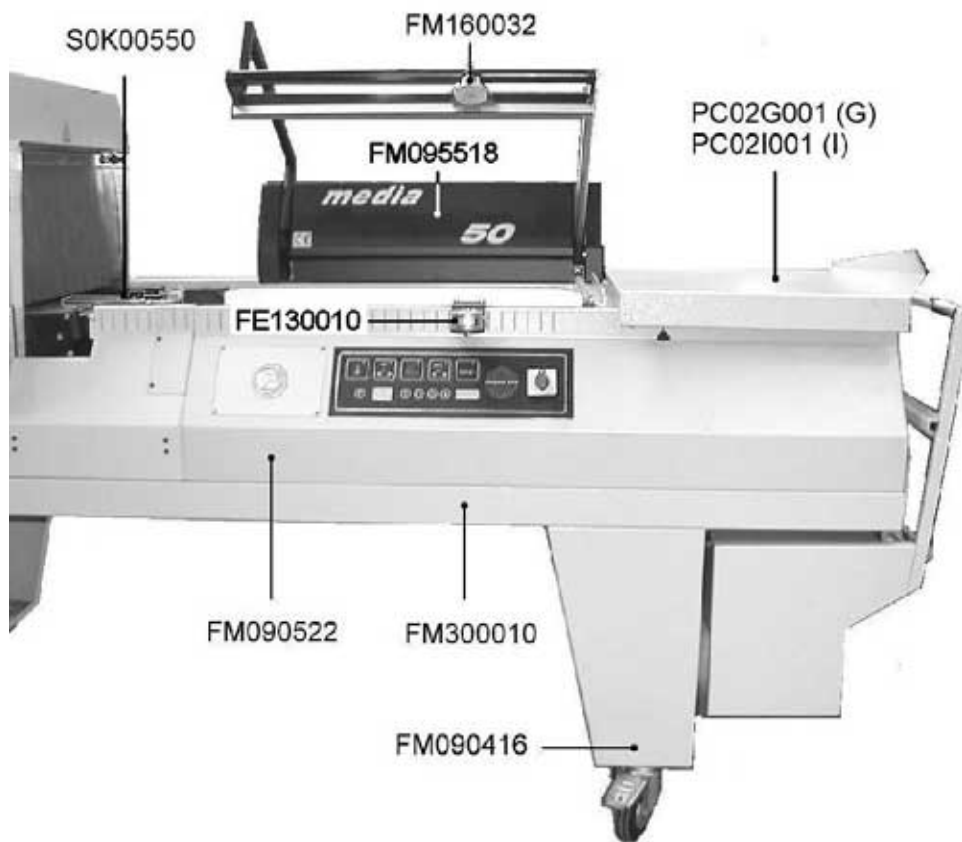

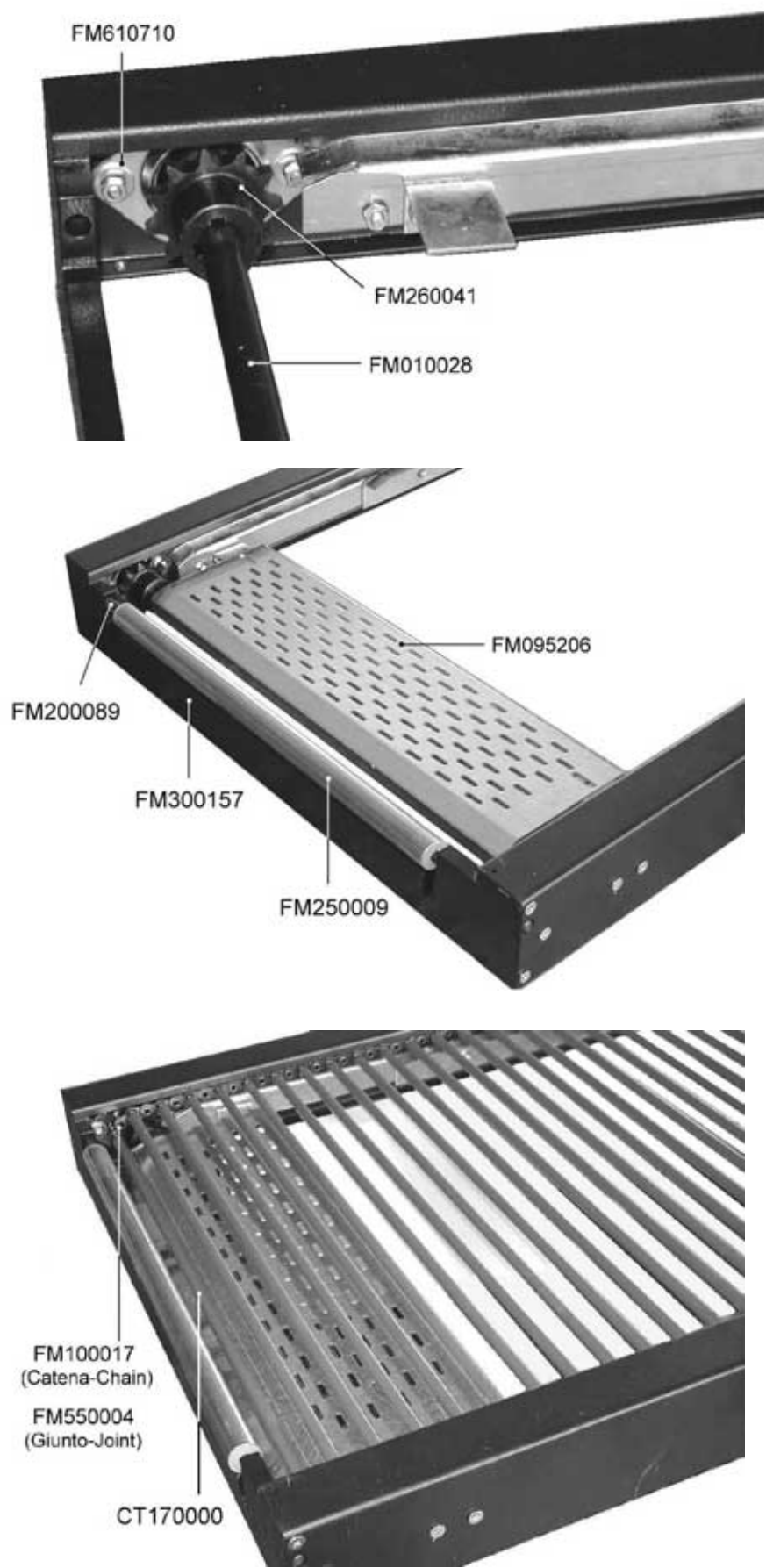

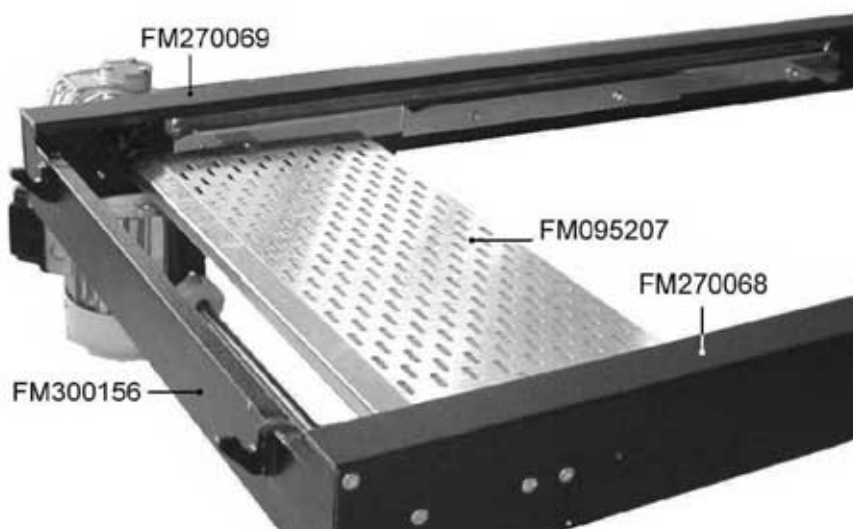
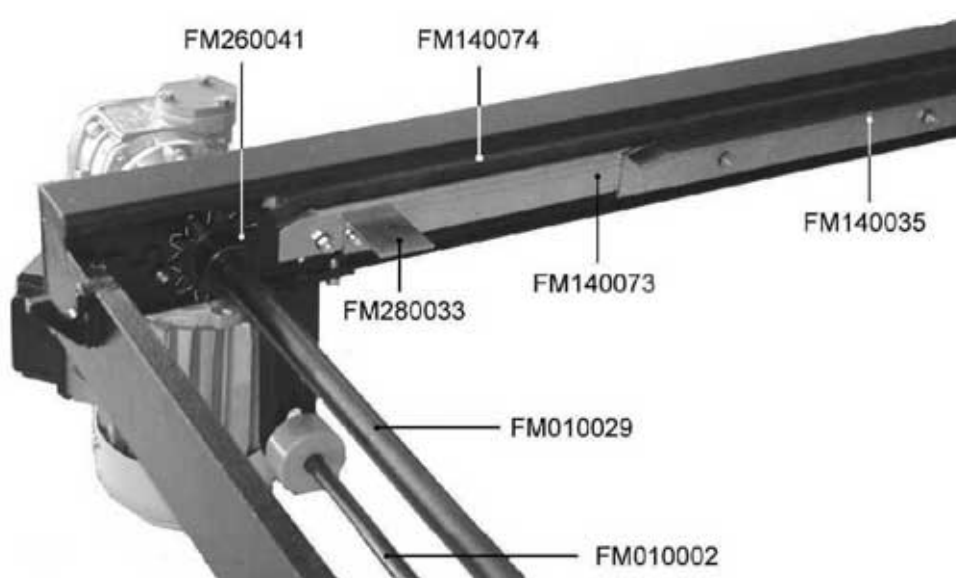
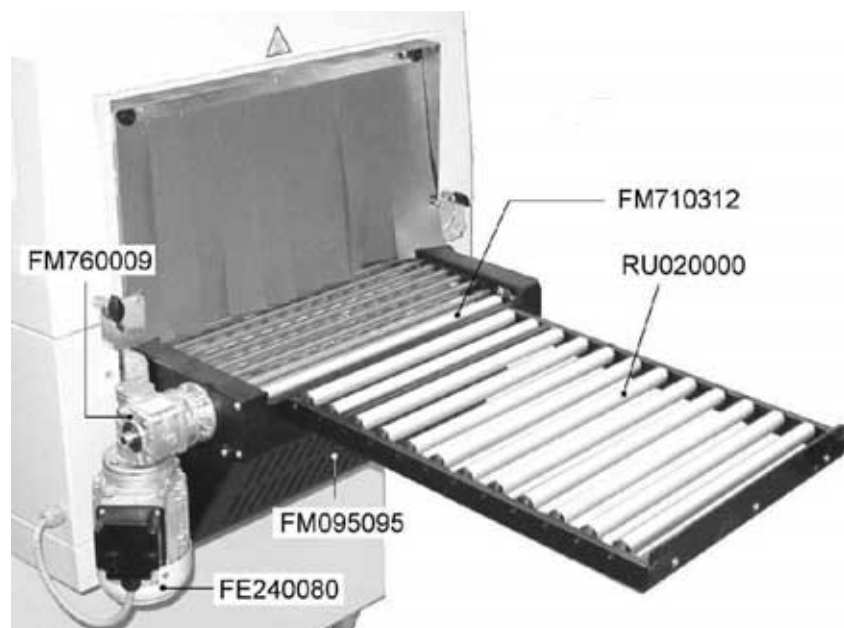

GRUPPO NASTRO TRASPORTATORE (interno tunnel)
CONVEYOR BELT GROUP (tunnel inside)

TAVOLA 8
SCHEME 8

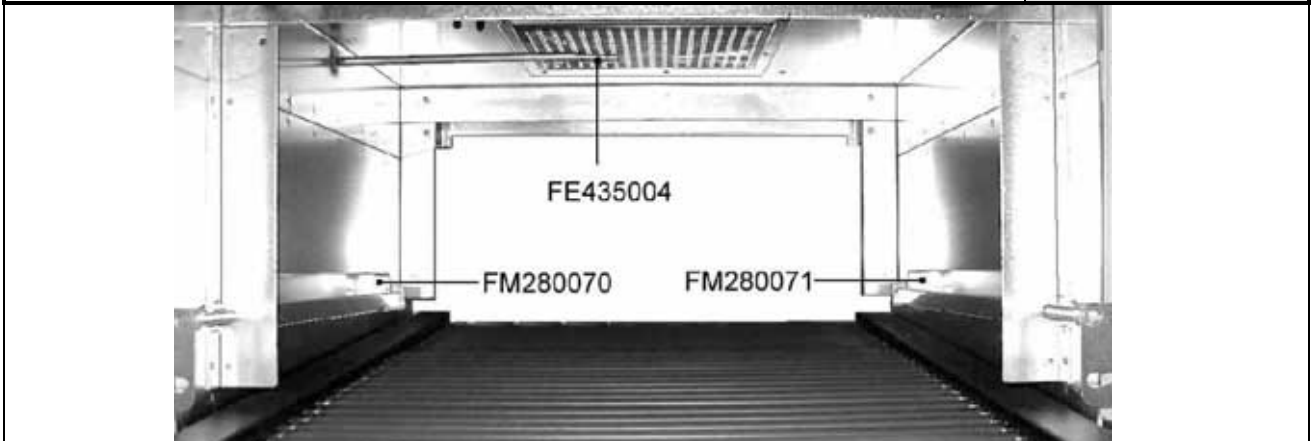

GRUPPO NASTRO TRASPORTATORE (catena)
CONVEYOR BELT GROUP (chain)

TAVOLA 8A
SCHEME 8A

CT170000: Catena completa per nastro trasportatore
 Chain group for conveyor belt

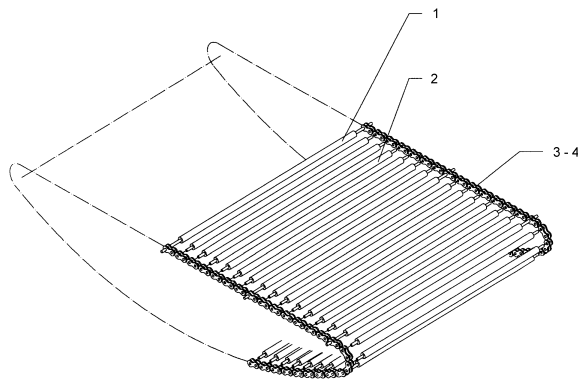

| POS. Pos. | CODICI PARTICOLARI Items | DENOMINAZIONI PARTICOLARI Items description | Q.tà |
|--------------|-----------------------------|--|------|
| 1 | AS250048 | Rullino di contenimento catena Chain holding roller | 9 |
| 2 | AS250047 | Rullino per catena Chain roller | 64 |
| 3 | FM100017 | Catena a perni forati p.1/2" lg.1841.5 Perforated pin chain p.1/2" lg.1841.5 | 2 |
| 4 | FM550004 | Giunto Joint | 2 |

GRUPPO NASTRO TRASPORTATORE (Teflon)
CONVEYOR BELT GROUP (Teflon)

TAVOLA 8B
SCHEME 8B



**GRUPPO MOTORE + RESISTORI
MOTOR + HEATERS GROUP**

**TAVOLA 9
SCHEME 9**

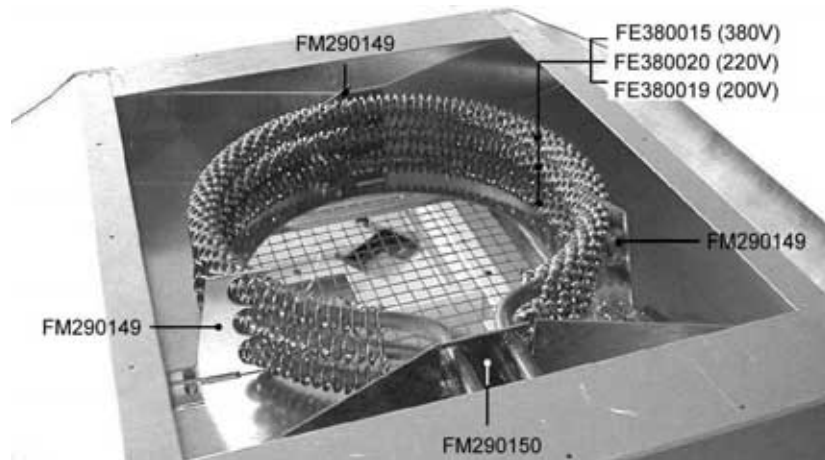
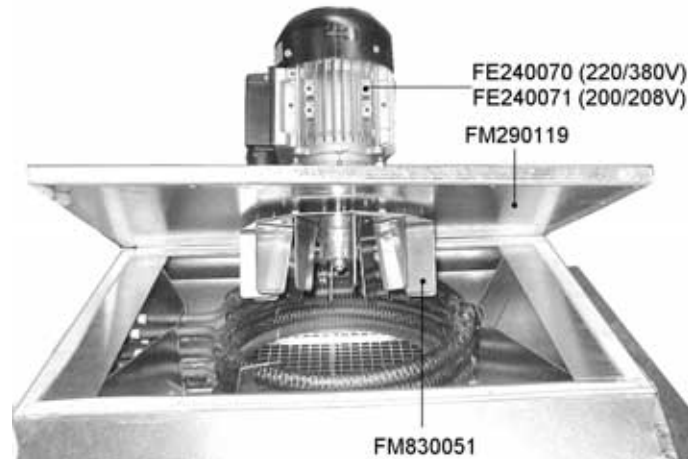

**GRUPPO TENDINE
CURTAIN GROUP**

**TAVOLA 9A
SCHEME 9A**

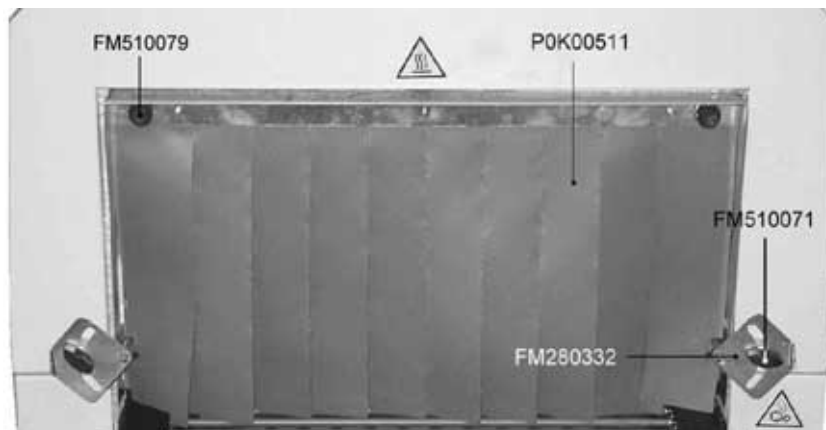
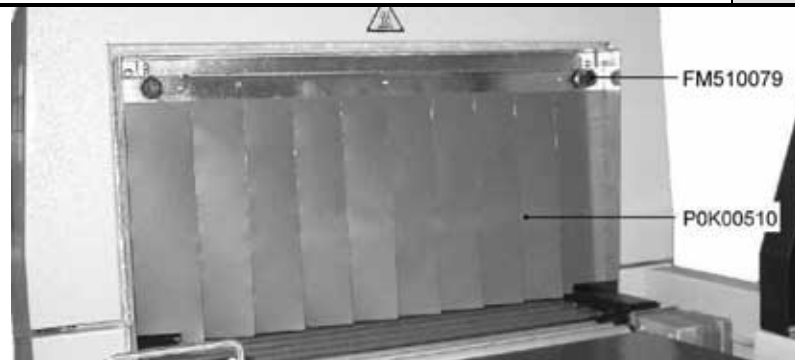

GRUPPO ELETTRICO (pannello comandi)
WIRING GROUP (control panel)

TAVOLA 10
SCHEME 10



GRUPPO ELETTRICO (cassetto)
WIRING GROUP (box)

TAVOLA 10A
SCHEME 10A

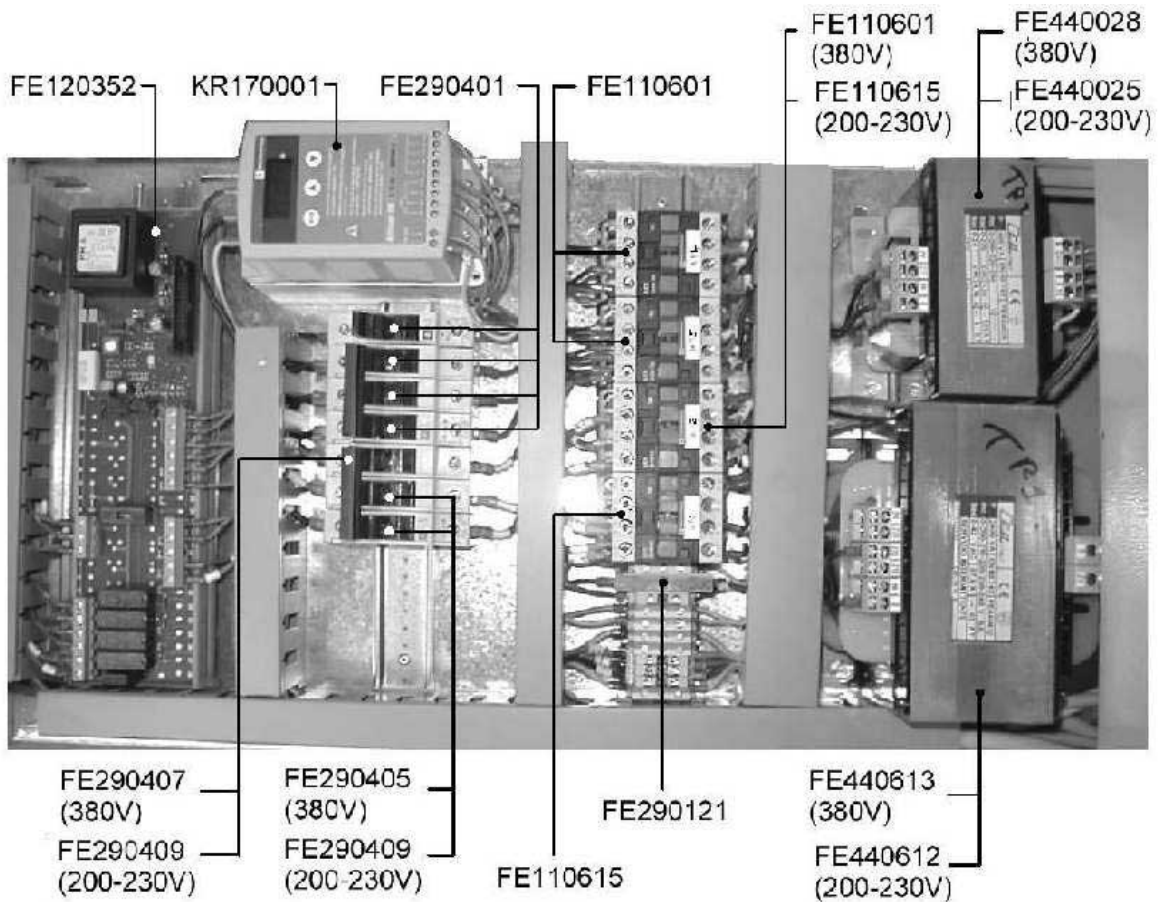

SCHEMA ELETTRICO WIRING DIAGRAM

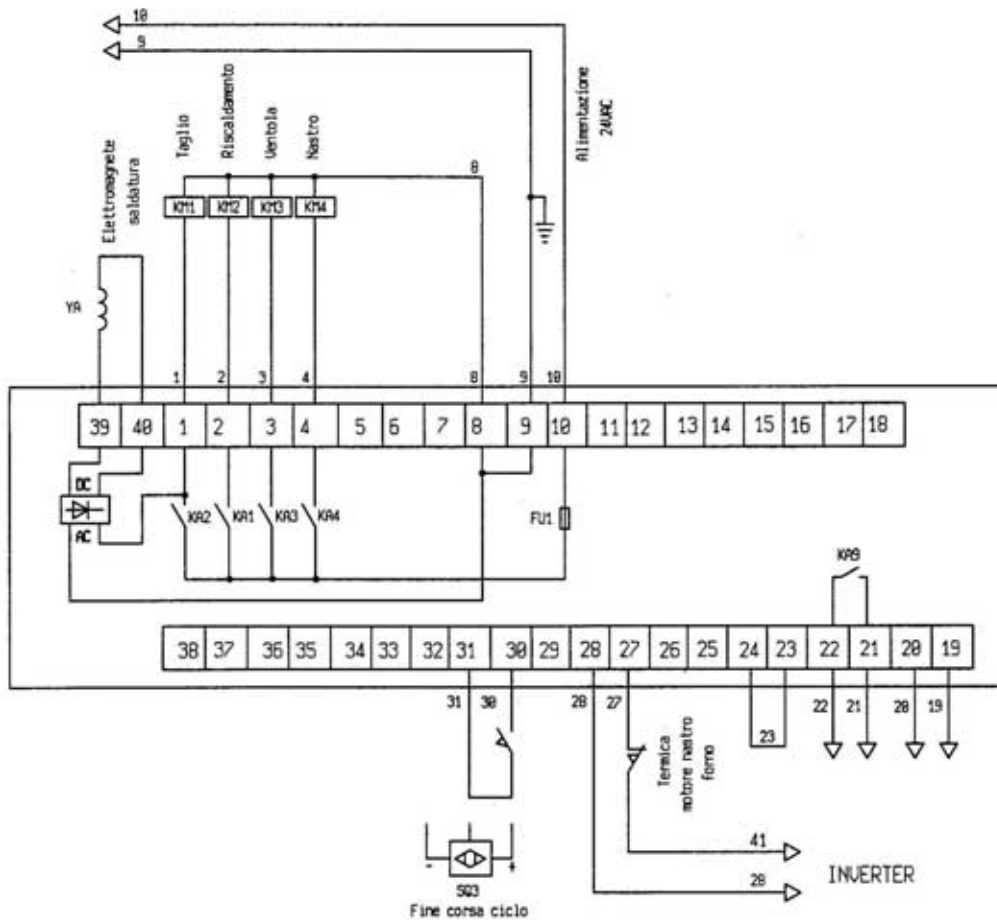
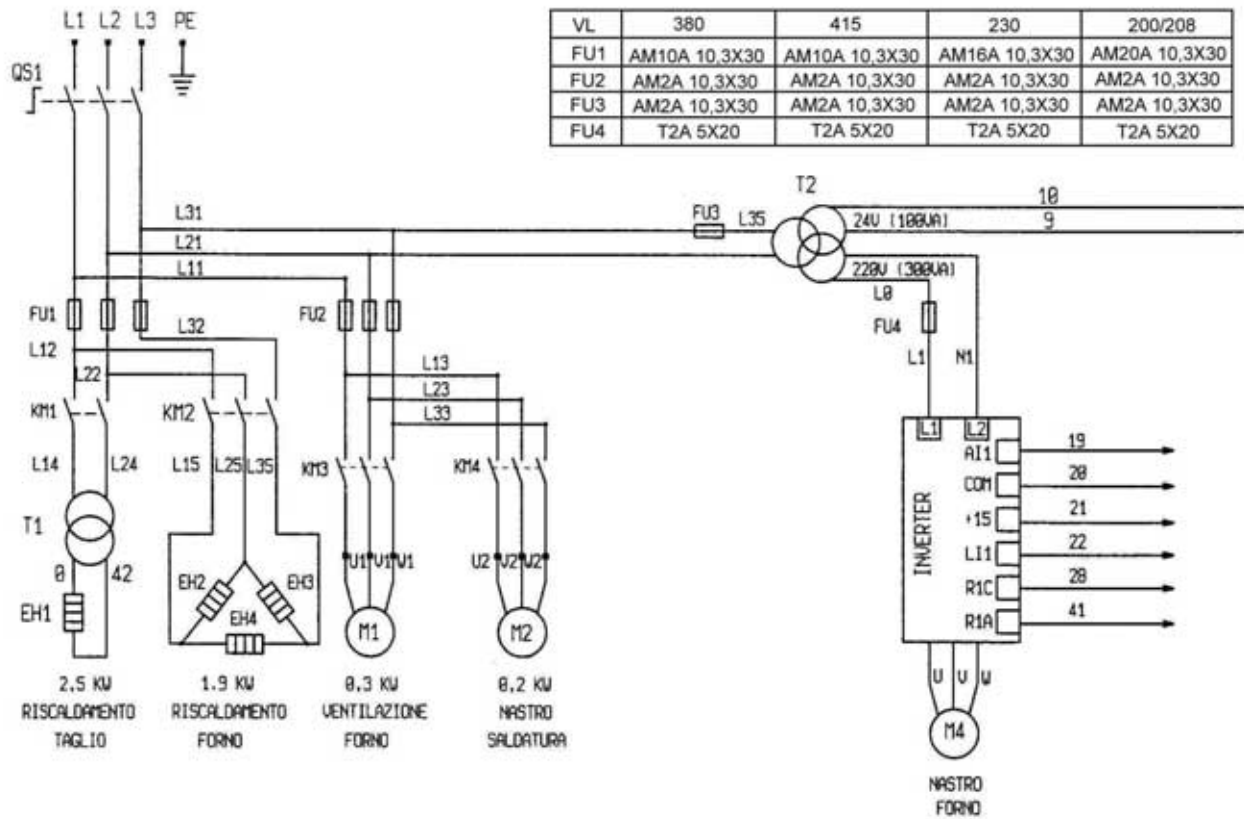

LEGENDA SCHEMA ELETTRICO WIRING DIAGRAM DESCRIPTION

| | |
|-----|---|
| QS1 | Interruttore generale / Main switch |
| EH1 | Resistenza di taglio / Cutting resistance |
| EH2 | Resistori forno / Oven resistors |
| EH3 | Resistori forno / Oven resistors |
| EH4 | Resistori forno / Oven resistors |
| M1 | Motore ventola / Fan motor |
| M2 | Motore nastro / Belt motor |
| M4 | Motore nastro forno / Belt Oven motor |
| T1 | Trasformatore di taglio / Cut transformer |
| T2 | Trasformatore ausiliario / Auxiliary transformer |
| SQ3 | Fine corsa ciclo / Safety device cutting out limit switch |
| KM1 | Contattore taglio / Cutting contactor |
| KM2 | Contattore resistori forno / Oven resistors' contactor |
| KM3 | Contattore ventola forno / Fan contactor |
| KM4 | Contattore nastro / Sealing Belt contactor |
| YA | Elettromagnete saldatura / Sealing magnet |



Minipack-torre S.p.A.

Via Provinciale, 54 - 24044 DALMINE (BG) - ITALY

Tel. (035) 563525 – Fax (035) 564945

E-mail: info@minipack-torre.it

<http://www.minipack-torre.it>